

Please check the examination details below before entering your candidate information

Candidate surname

Other names

Centre Number

Candidate Number

--	--	--	--	--

--	--	--	--	--

Pearson Edexcel International GCSE

Friday 19 May 2023

Morning (Time: 2 hours)

Paper
reference

4MA1/1FR

Mathematics A

PAPER 1FR

Foundation Tier



You must have: Ruler graduated in centimetres and millimetres, protractor, pair of compasses, pen, HB pencil, eraser, calculator. Tracing paper may be used.

Total Marks

Instructions

- Use **black** ink or ball-point pen.
- **Fill in the boxes** at the top of this page with your name, centre number and candidate number.
- Answer **all** questions.
- Without sufficient working, correct answers may be awarded no marks.
- Answer the questions in the spaces provided
– *there may be more space than you need.*
- **Calculators may be used.**
- You must **NOT** write anything on the formulae page.
Anything you write on the formulae page will gain **NO** credit.

Information

- The total mark for this paper is 100.
- The marks for **each** question are shown in brackets
– *use this as a guide as to how much time to spend on each question.*

Advice

- Read each question carefully before you start to answer it.
- Check your answers if you have time at the end.

Turn over ►

P72789A

©2023 Pearson Education Ltd.

N:1/1/1



P 7 2 7 8 9 A 0 1 2 8



Pearson

International GCSE Mathematics
Formulae sheet – Foundation Tier

Area of trapezium = $\frac{1}{2}(a + b)h$

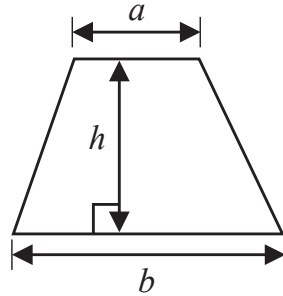

Volume of prism = area of cross section \times length

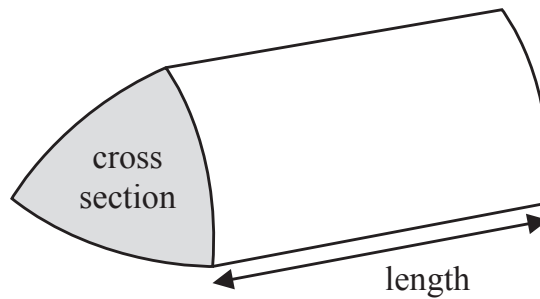

Volume of cylinder = $\pi r^2 h$

Curved surface area of cylinder = $2\pi r h$

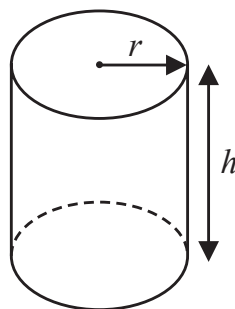

Answer ALL TWENTY EIGHT questions.

Write your answers in the spaces provided.

You must write down all the stages in your working.

1 The table shows the number of steps Polly walked on each of five days.

Day	Number of steps
Monday	8 927
Tuesday	11 362
Wednesday	9 653
Thursday	10 980
Friday	6 411

(a) On which of these days did Polly walk the greatest number of steps?

Tuesday (1)

(1)

(b) Write the number 9653 in words.

Nine thousand six hundred and fifty three (1)

(1)

(c) Write the number 8927 correct to the nearest ten.

8930 (1)

(1)

(d) Write down the value of the 9 in the number 10980

9 hundreds (1)

(1)

(e) Work out the sum of the number of steps Polly walked on Thursday and on Friday.

$$\begin{array}{r} 10\ 980 \\ + 6\ 411 \\ \hline 17\ 391 \end{array}$$

17 391 (1)

(1)

(Total for Question 1 is 5 marks)

2 The diagram shows a fair spinner with six sections.

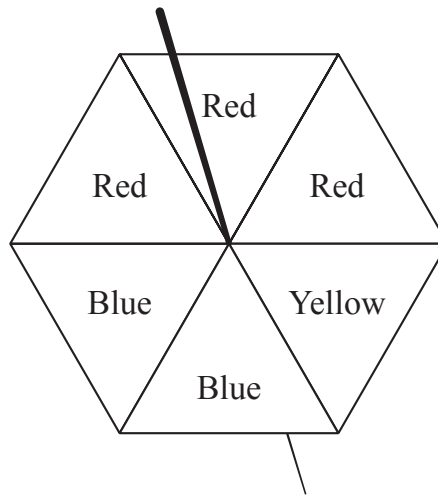

Three sections are red, two sections are blue and one section is yellow.

impossible unlikely evens likely certain

The spinner is spun once.

(a) Write down a word from the box to describe the likelihood that the spinner lands on yellow.

$$\frac{1}{6}$$

unlikely (1)

(1)

(b) On the probability scale, mark with a cross (×) the probability that the spinner lands on green.

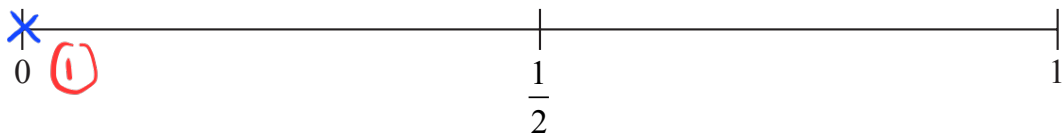

(1)

Here are 8 number cards.

3 of the number cards are blank.



(1)

Hugo is going to take at random one of these cards.

(c) Write a number on each of the 3 blank cards so that the probability that Hugo picks a card with an odd number is $\frac{1}{2}$

(1)

(Total for Question 2 is 3 marks)

3 The diagram shows a 5-sided polygon, $ABCDE$

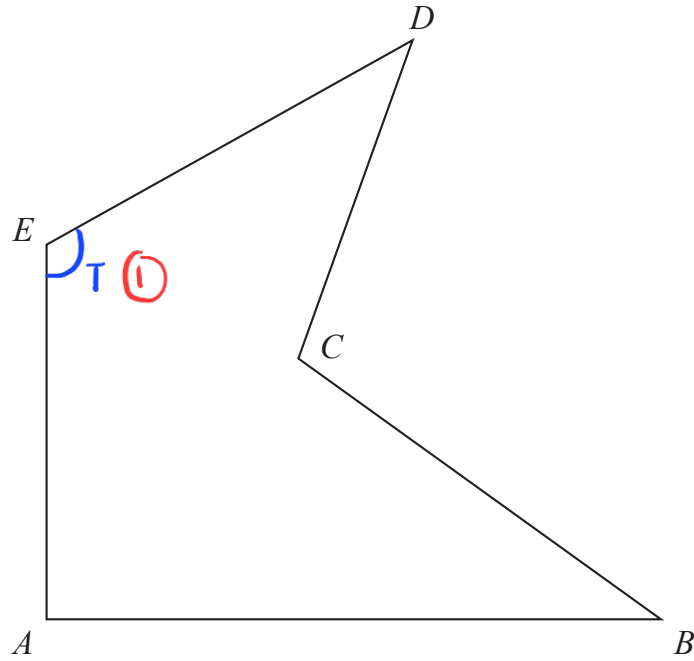

(a) Write down the mathematical name for a 5-sided polygon.

..... pentagon (1)

(1)

(b) Measure the length of the line AB
Give your answer in centimetres.

..... 7.6 (1) cm

(1)

(c) On the diagram, mark an obtuse angle with the letter T

$90^\circ < \theta < 180^\circ$

(1)

(Total for Question 3 is 3 marks)

4 Here is a shape made of squares.

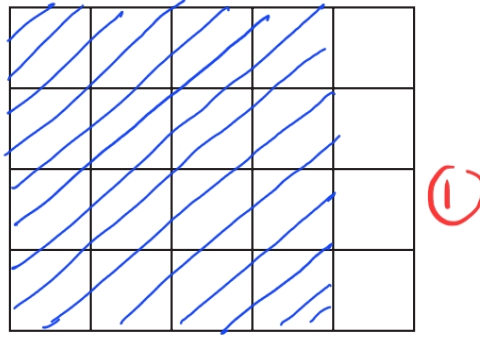

(a) Shade $\frac{4}{5}$ of the shape. $\frac{4}{5} \times 20 = 16$

(1)

(b) Write 0.7 as a percentage.

$$0.7 \times 100\% = 70\%$$

70 (1)

%

(1)

(c) Write these decimals in order of size.
Start with the smallest decimal.

0.49 0.459 0.4 0.049 0.14

0.049, 0.14, 0.4, 0.459, 0.49 (1)

(1)

(Total for Question 4 is 3 marks)

5 Here are the first four terms of a number sequence.

2 6 10 14

Elsie correctly works out that the next term in the sequence is 18

(a) Explain how she was able to work this out.

Add 4 (1)

(1)

(b) Explain why 217 cannot be a number in the sequence.

All terms in the sequence are even. (1)

(1)

(Total for Question 5 is 2 marks)

6 Niran is organising a baking competition and needs to buy 9.25 kilograms of flour.

Flour is sold in bags that each contain 750 grams of flour.

Each of these bags costs 58 Baht.

Niran can only buy whole bags of flour.

Niran buys the least number of bags of flour that he needs.

Work out the cost of the flour that he buys.

$$9.25 \times 1000 = 9250 \text{ g} \quad (1)$$

$$\begin{aligned} \text{No. of bags} &= \frac{9250 \text{ g}}{750 \text{ g}} = 12.333\dots \\ \text{needed} &= 13 \text{ bags needed} \quad (1) \end{aligned}$$

$$\begin{aligned} \text{Total cost} &= 13 \times 58 \quad (1) \\ &= 754 \quad (1) \end{aligned}$$

754

..... Baht

(Total for Question 6 is 4 marks)

7 (a) Simplify $6a \times 2c$

$$12ac \quad (1)$$

(1)

(b) Simplify $4d + 3e + d - 5e$

$$4d + d + 3e - 5e$$

$$= 5d - 2e$$

$$5d - 2e \quad (2)$$

(2)

(c) Solve $4x - 7 = 23$

$$4x = 30 \quad (1)$$

$$x = \frac{30}{4} = 7.5 \quad (1)$$

$$x = 7.5$$

(2)

(Total for Question 7 is 5 marks)

8 (a) Write down the prime number that lies between 90 and 100

$$97 \quad (1)$$

(1)

(b) Find the cube root of 79507

$$\sqrt[3]{79507} = 43$$

$$43 \quad (1)$$

(1)

(c) Work out the value of $4^2 \times 5^3$

$$16 \times 125 = 2000$$

$$(1) \quad (1)$$

$$2000$$

(2)

(Total for Question 8 is 4 marks)

- 9 The pictogram gives some information about the number of cars sold by each of the four employees of Best Cars in April.

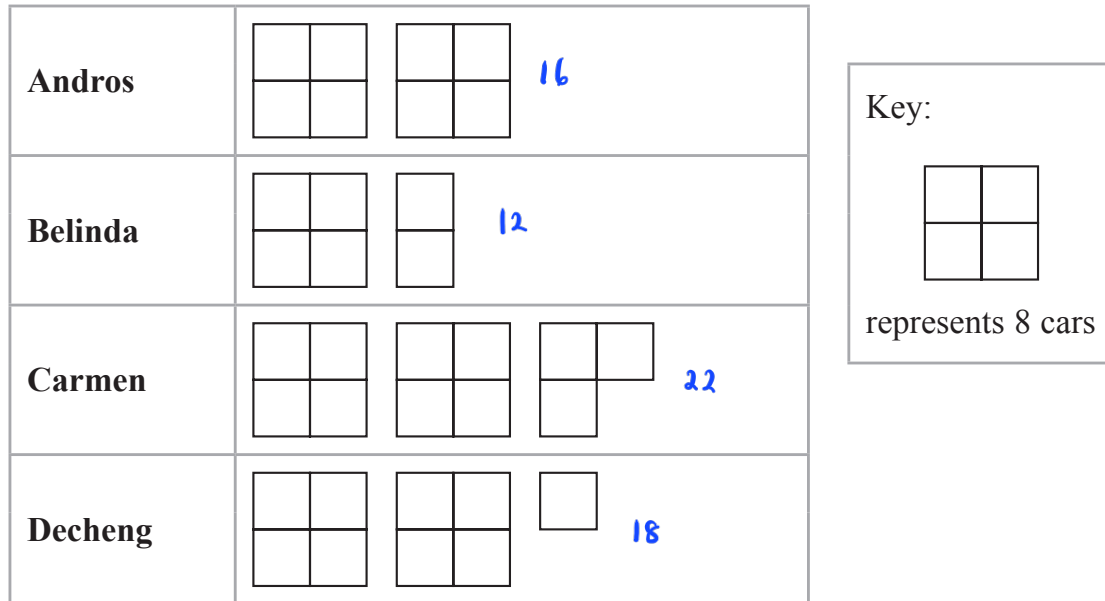

In March, Best Cars sold 60 cars in total.

Its target for April was to sell 15% more cars in total than it sold in March.

Show that Best Cars did not meet its target.

Show your working clearly.

$$\text{Total cars sold in April : } 16 + 12 + 22 + 18 = 68 \text{ cars } \textcircled{1}$$

$$60 \times 1.15 = 69 \text{ cars}$$

$$\textcircled{1} \quad \textcircled{1}$$

\therefore Best Cars sold 1 car less from achieving its target.

(Total for Question 9 is 4 marks)

10 The diagram shows quadrilateral $ABCD$

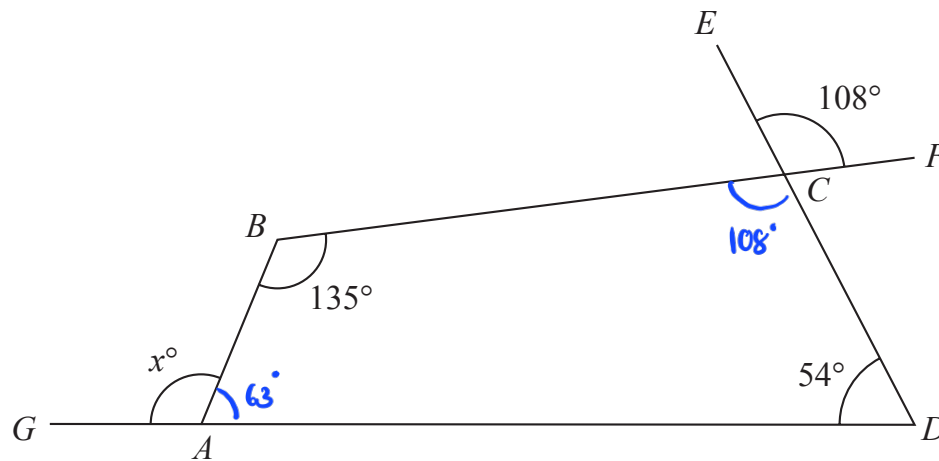

Diagram NOT accurately drawn

ECD , BCF and GAD are straight lines.

Work out the value of x

Give a reason for each stage of your working.

$$\text{angle } BCD = \text{angle } ECF = 108^\circ \quad (1)$$

(vertically opposite angles are equal)

$$\text{angle } BAD = 360^\circ - 135^\circ - 108^\circ - 54^\circ = 63^\circ \quad (1)$$

(angles in a quadrilateral add up to 360°) (1)

$$x^\circ = 180^\circ - 63^\circ$$
$$= 117^\circ \quad (1)$$

(angles on a straight line add up to 180°) (1)

$$x = \dots\dots\dots 117$$

(Total for Question 10 is 5 marks)

11 The table shows how many cousins each of 30 students in Class A has.

Number of cousins	Frequency
0	3
1	7
2	6
3	11
4	1
5	2

(a) Work out the range of the number of cousins.

$$5 - 0 = 5$$

5 (1)

(1)

(b) Write down the mode of the number of cousins.

3 (1)

(1)

(c) Work out the mean of the number of cousins.

$$\begin{aligned} \text{mean} &= \frac{(0 \times 3) + (1 \times 7) + (2 \times 6) + (3 \times 11) + (4 \times 1) + (5 \times 2)}{30} \\ &= \frac{7 + 12 + 33 + 4 + 10}{30} \\ &= \frac{66}{30} = 2.2 \end{aligned}$$

2.2

(3)

(Total for Question 11 is 5 marks)

12 On the grid, draw the graph of $y = 4 - 2x$ for values of x from -1 to 4

x	-1	0	1	2	3	4
y	6	4	2	0	-2	-4

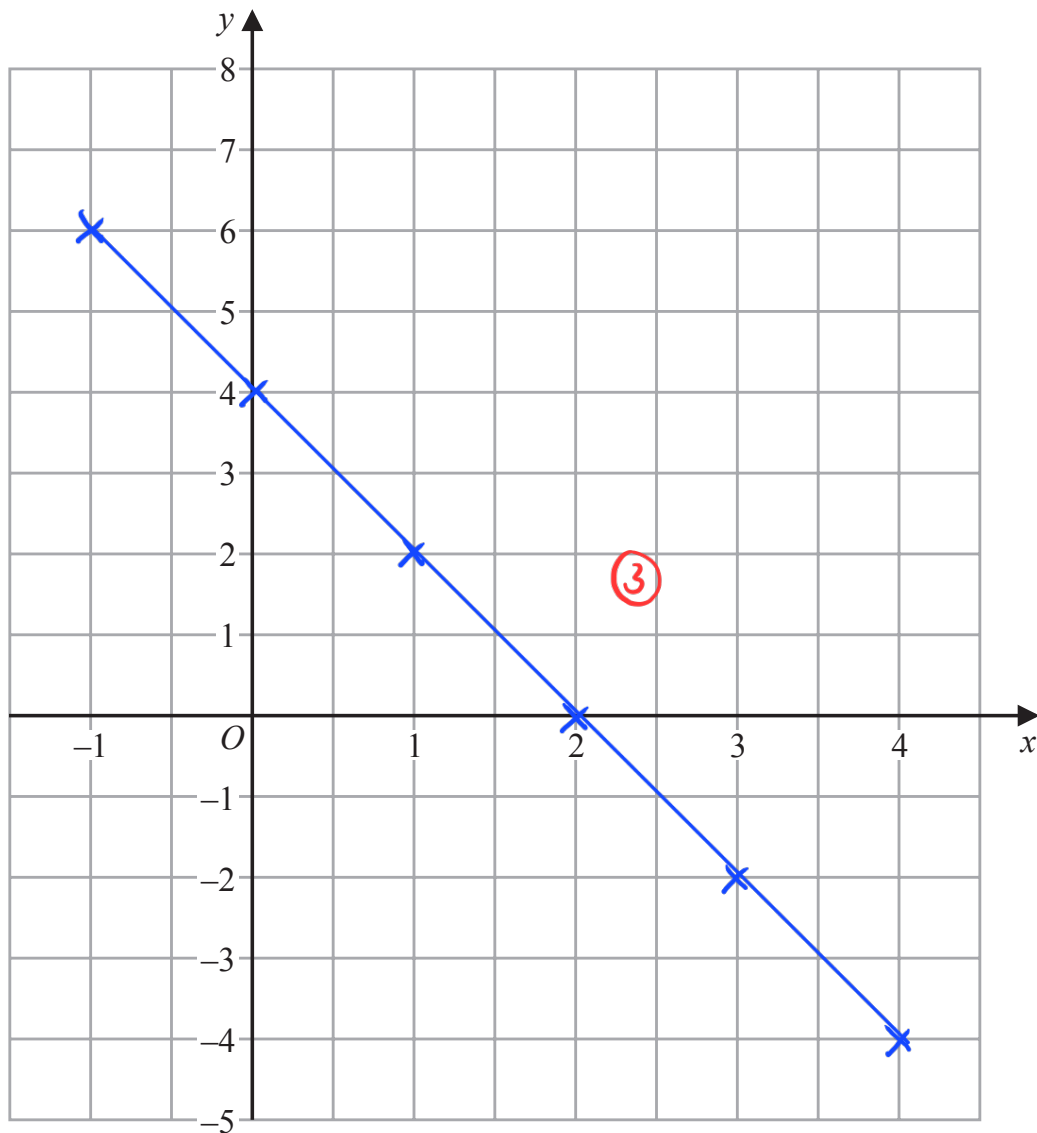

(Total for Question 12 is 3 marks)

13 The diagram shows the plan of a garden.

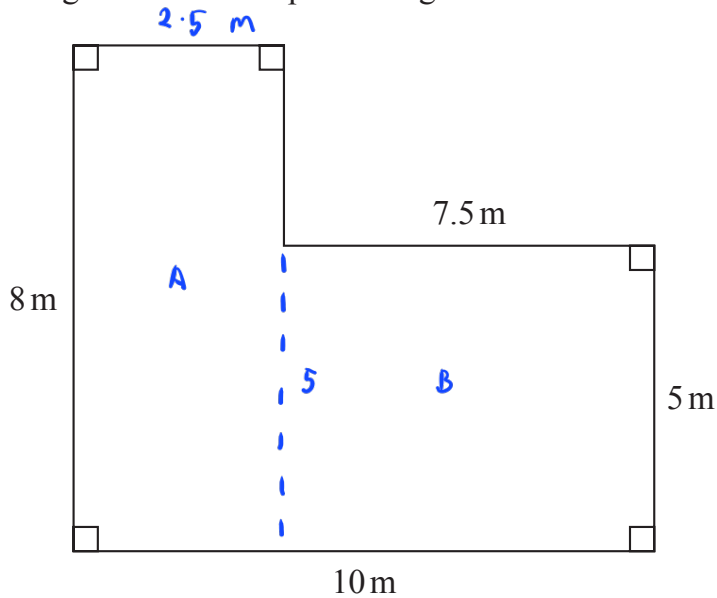
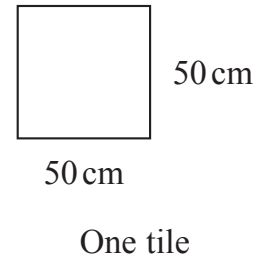

Diagram NOT accurately drawn



Martyn covers the garden with square tiles of side length 50 cm. There are no gaps between the tiles.

It takes 4 minutes to lay each tile.

Work out how long it takes Martyn to cover the whole garden with tiles. Give your answer in hours and minutes.

$$\text{Area A} = 8 \times 2.5 = 20 \text{ m}^2$$

$$\text{Area B} = 7.5 \times 5 = 37.5 \text{ m}^2$$

$$\begin{aligned} \text{Area of one tile} &= 0.5 \times 0.5 \\ &= 0.25 \text{ m}^2 \end{aligned}$$

$$\text{Total area} = 20 + 37.5 = 57.5 \text{ m}^2$$

$$\text{No. of tiles required} = \frac{57.5 \text{ m}^2}{0.25 \text{ m}^2} = 230 \text{ tiles}$$

$$\text{Time taken} = 230 \times 4 \text{ mins} = 920 \text{ mins}$$

$$\begin{aligned} \text{in hours} &= \frac{920}{60} = 15 \frac{1}{3} \text{ hours} \\ &= 15 \text{ hours } 20 \text{ mins} \end{aligned}$$

..... 15 hours 20 minutes

(Total for Question 13 is 5 marks)

- 14 A small bag of grain contains 2 kg of grain.
A large sack of grain contains 7 kg of grain.

Makenna buys r small bags of grain and h large sacks of grain.

The total amount of grain Makenna buys is F kg.

Write down a formula for F in terms of r and h

$$F = 2r + 7h$$

$$F = 2r + 7h \quad (3)$$

(Total for Question 14 is 3 marks)

- 15 Show that $\frac{3}{5} + \frac{2}{7} = \frac{31}{35}$

$$\frac{3 \times 7}{5 \times 7} + \frac{2 \times 5}{7 \times 5}$$

$$= \frac{21}{35} + \frac{10}{35} \quad (1)$$

$$= \frac{31}{35} \quad (1)$$

(Total for Question 15 is 2 marks)

16 Roland, Seiso and Tim share the total cost of buying a plot of land.

Roland and Seiso share some of the cost in the ratio 2:5

Roland's share of the cost is \$1700

Tim's share of the cost is \$2150 **more** than Roland's share.

Work out the total cost of buying the plot of land.

$$\text{Seiso's share} = \frac{1700}{2} \times 5 = 4250 \quad (2)$$

$$\text{Tim's share} = 2150 + 1700 = 3850$$

$$\text{Total cost} = 4250 + 3850 + 1700 \quad (1)$$

$$= 9800 \quad (1)$$

\$.....9800

(Total for Question 16 is 4 marks)

- 17 Write 2250 as a product of powers of its prime factors.
Show your working clearly.

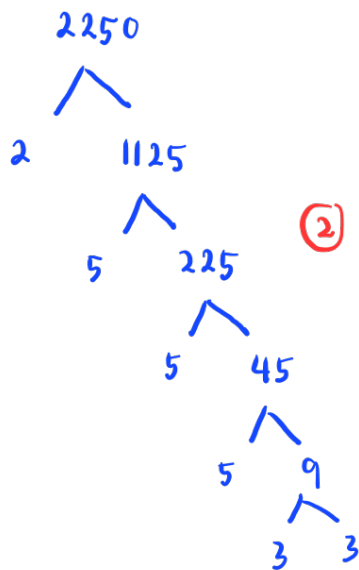

$$2 \times 3^2 \times 5^3 = 2250$$

①

$$2 \times 3^2 \times 5^3$$

(Total for Question 17 is 3 marks)

18 Here is a Venn diagram.

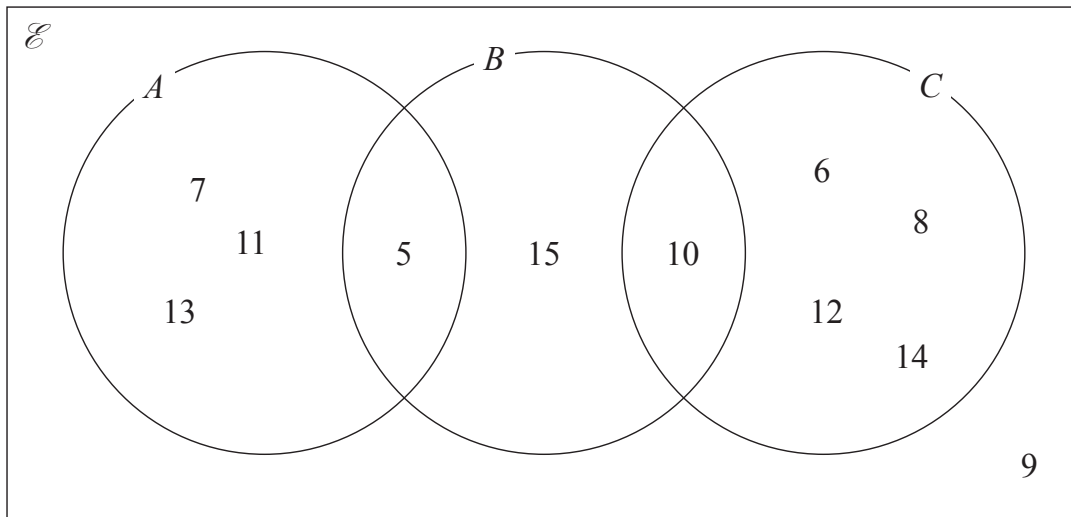

(a) Write down the numbers that are in the set

(i) A

7, 11, 13, 5 (1)

(1)

(ii) $B \cup C$

5, 6, 8, 10, 12, 14, 15 (1)

(1)

Dominic writes down $9 \notin C$

(b) Explain why Dominic is correct.

9 is not a member of C (1)

(1)

(Total for Question 18 is 3 marks)

19 $ABCD$ and $EFGH$ are similar quadrilaterals.

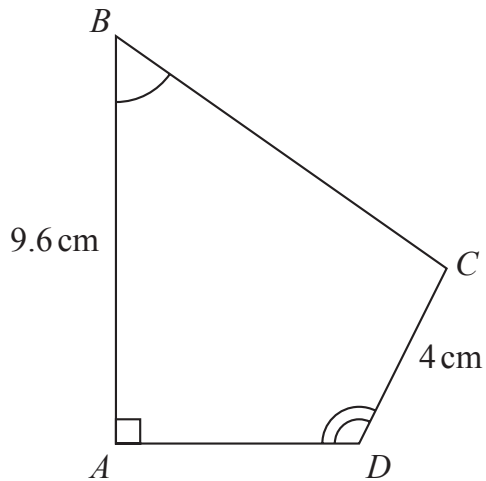
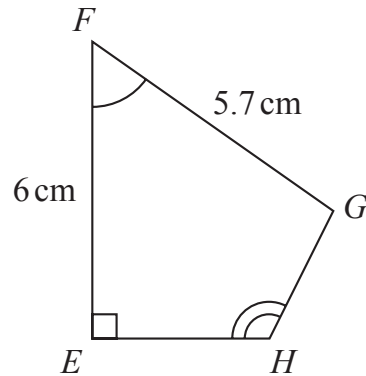

Diagram NOT accurately drawn



(a) Work out the length of GH

$$GH = \frac{6}{9.6} \times 4 = 2.5$$

2.5
..... cm
(2)

(b) Work out the length of BC

$$BC = \frac{9.6}{6} \times 5.7 = 9.12$$

9.12
..... cm
(2)

(Total for Question 19 is 4 marks)

- 20 The diagram shows a shape made up of three semicircles, enclosing a right-angled triangle.

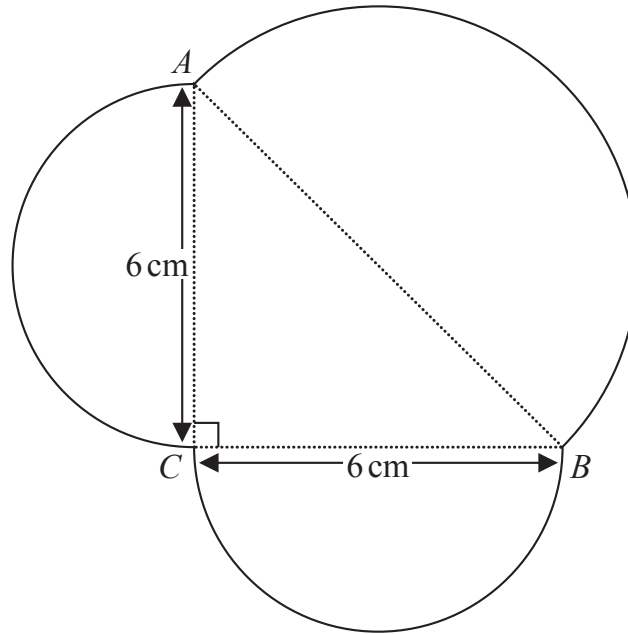

Diagram **NOT** accurately drawn

AB , BC and CA are each the diameter of a semicircle.

$$BC = CA = 6 \text{ cm.}$$

Work out the perimeter of the shape.

Give your answer correct to one decimal place.

$$AB^2 = 6^2 + 6^2$$

$$AB^2 = 72 \quad (1)$$

$$AB = \sqrt{72} = 8.48\dots \quad (1)$$

$$\text{Perimeter} = \frac{1}{2} \times \pi \times 6 + \frac{1}{2} \times \pi \times 6 + \frac{1}{2} \times \pi \times 8.48\dots \quad (1)$$

$$= 3\pi + 3\pi + 4.24\pi \quad (1)$$

$$= 10.24\pi$$

$$= 32.17\dots$$

$$\approx 32.2 \text{ (1 d.p.)}$$

(1)

32.2

cm

(Total for Question 20 is 5 marks)

21 Each time Evie plays a game against her computer, she will win or lose.

For each game, the probability that Evie will win is 0.74

Evie is going to play 300 games against her computer.

Work out an estimate for the number of games that Evie will lose.

$$\text{Probability losing} = 1 - 0.74 = 0.26 \quad (1)$$

$$0.26 \times 300 = 78$$

(1)

78

(Total for Question 21 is 2 marks)

22 (a) Simplify $m^{10} \div m^3$

$$m^{10-3} = m^7 \quad (1)$$

m^7

(1)

$$k^n \times k^4 = k^{12}$$

(b) Write down the value of n

$$k^{n+4} = k^{12}$$

$$n+4 = 12$$

$$n = 8 \quad (1)$$

$$n = 8$$

(1)

(c) Simplify $(3x^6y^8)^2$

$$\begin{aligned} & 3^2 \times x^{6 \times 2} \times y^{8 \times 2} \\ & = 9x^{12}y^{16} \quad (2) \end{aligned}$$

$9x^{12}y^{16}$

(2)

(Total for Question 22 is 4 marks)

23 (a) Expand $4x(x - 5)$

$$= 4x^2 - 20x$$

$$4x^2 - 20x \quad (1)$$

(1)

(b) Factorise $y^2 - 9y + 20$

$$(y - 5)(y - 4) \quad (2)$$

(2)

(Total for Question 23 is 3 marks)

24 (a) Write 5.6×10^{-3} as an ordinary number.

$$0.0056 \times 10^{-3}$$

$$0.0056 \quad (1)$$

(1)

(b) Work out $\frac{6 \times 10^3}{2.1 \times 10^{-4} + 9 \times 10^{-5}}$

Give your answer in standard form.

$$2.1 \times 10^{-4} + 0.9 \times 10^{-4} = 3 \times 10^{-4}$$

$$\frac{6 \times 10^3}{3 \times 10^{-4}} = \frac{6}{3} \times 10^{3 - (-4)} \\ = 2 \times 10^7 \quad (1)$$

$$2 \times 10^7$$

(2)

(Total for Question 24 is 3 marks)

- 25 Kazi buys a car for 700 000 taka.
The value of the car depreciates by 12% each year.
Work out the value of the car at the end of 3 years.
Give your answer correct to the nearest taka.

$$\text{Value depreciation each year} = 1 - 0.12 = 0.88$$

$$\begin{aligned} \text{after 3 years} &= 700\,000 \times 0.88^3 \quad (2) \\ &= 477\,030 \quad (1) \end{aligned}$$

477 030

..... taka

(Total for Question 25 is 3 marks)

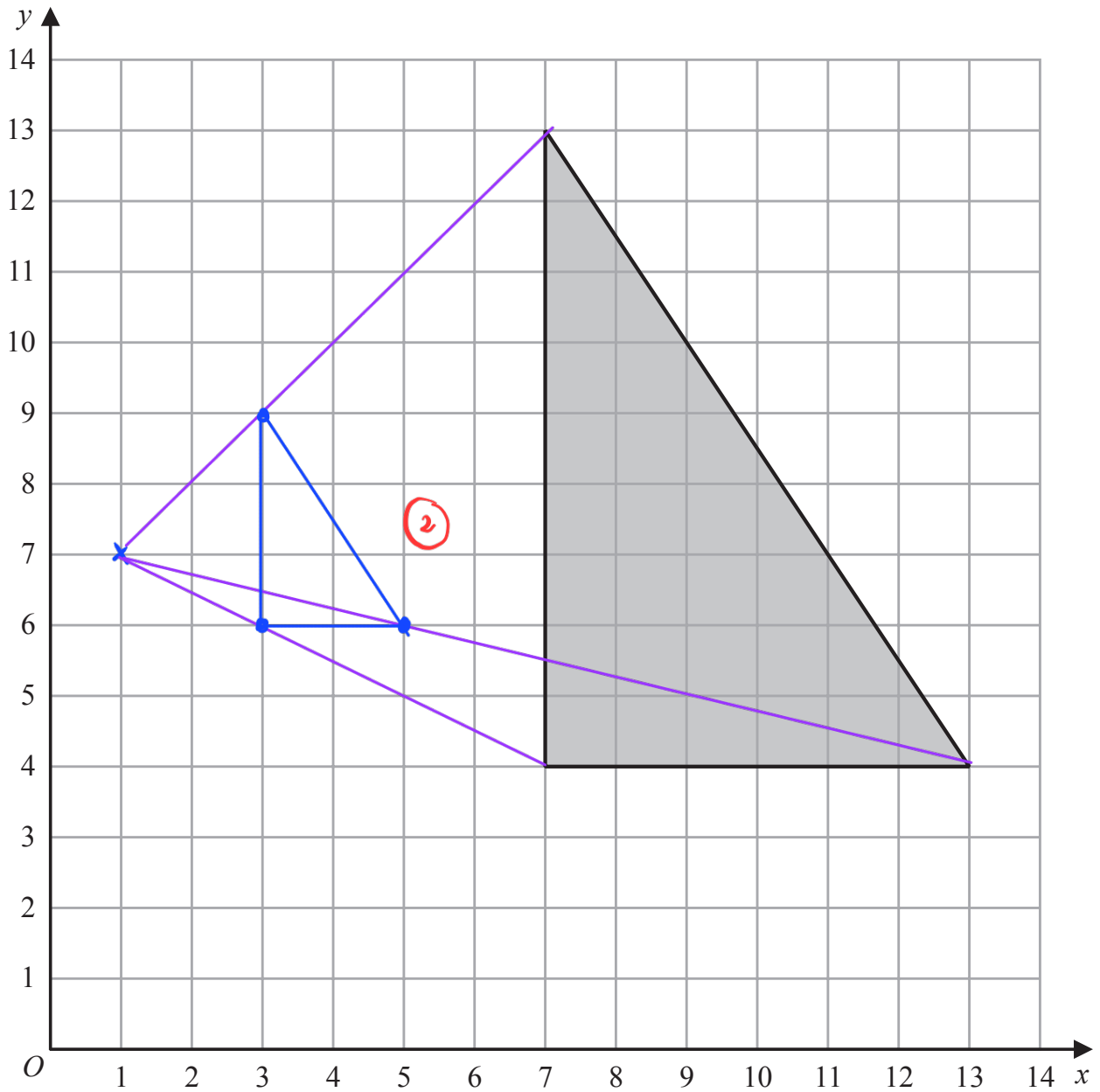

On the grid, enlarge the shaded shape with scale factor $\frac{1}{3}$ and centre (1, 7)

(Total for Question 26 is 2 marks)

27 The diagram shows a block of iron in the shape of a cuboid.

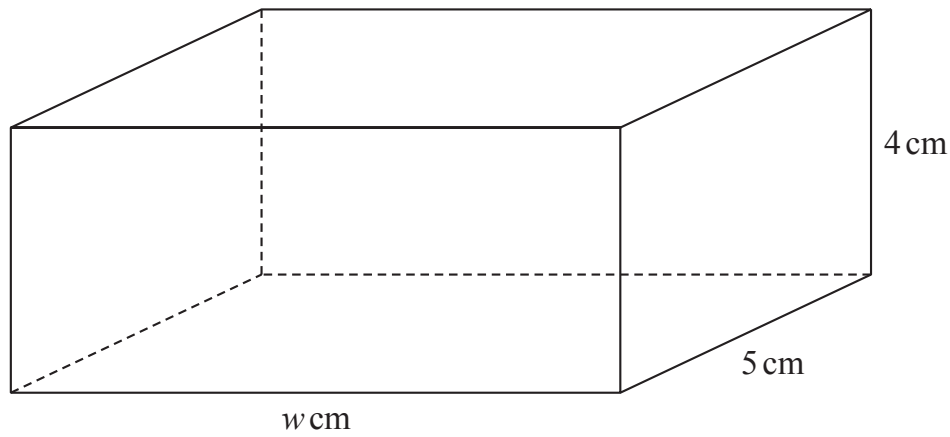

Diagram NOT
accurately drawn

The block has length w cm, width 5 cm and height 4 cm

The density of iron is 7.8 g/cm^3

The mass of the block is 1950 g

Work out the value of w

$$\text{density} = \frac{\text{mass}}{\text{volume}}$$

$$\text{Volume} = \frac{1950}{7.8} = 250 \text{ cm}^3 \quad (1)$$

$$250 = 5 \times 4 \times w$$

$$250 = 20w \quad (1)$$

$$w = \frac{250}{20} = 12.5 \quad (1)$$

$$w = \dots\dots\dots 12.5$$

(Total for Question 27 is 3 marks)

28 Moeen has a biased 6-sided dice.

The table gives information about the probability that, when the dice is thrown, it will land on each number.

Number	1	2	3	4	5	6
Probability	x	0.15	0.5	y	0.13	0.03

(a) Show that $x + y = 0.19$

$$x + y + 0.15 + 0.5 + 0.13 + 0.03 = 1 \quad (1)$$

$$x + y + 0.81 = 1$$

$$x + y = 1 - 0.81 = 0.19 \quad (1)$$

(2)

Given that $3x - y = 0.09$

and $x + y = 0.19$

(b) work out the value of x and the value of y
Show clear algebraic working.

$$x = 0.19 - y$$

$$3(0.19 - y) - y = 0.09 \quad (1)$$

$$0.57 - 3y - y = 0.09$$

$$-4y = -0.48$$

$$y = 0.12$$

$$x = 0.19 - 0.12 \quad (1)$$

$$= 0.07$$

$$x = \dots\dots\dots 0.07 \quad (1)$$

$$y = \dots\dots\dots 0.12$$

(3)

(Total for Question 28 is 5 marks)

TOTAL FOR PAPER IS 100 MARKS

BLANK PAGE

BLANK PAGE